

NOVAS



UNIVERSAL MECHANICAL 80MM CONCEALED CISTERN W/METAL FRAME FOR WALL HUNG TOILET

DETAILS

PRODUCT CODE
UNI1WCWHCB

DIMENSIONS
80mm x 500mm x 1140mm

MATERIAL
Plastic / Metal

PRODUCT SERIES
Universal

WELS RATING
3.3L/Min 4 STAR

WARRANTIES
15 Years Bracket / 5 Years Cistern

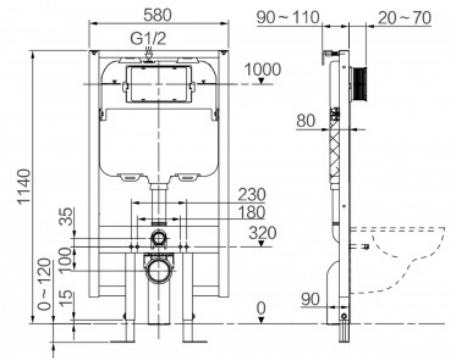

CERTIFICATIONS

